



LINEAR ACTUATORS

ATL 20 - BSA 20

ATL 25 - 28 – BSA 25 - 28

ATL 30 - BSA 30

ATL 40 - BSA 40

✿ Installation, Use and Maintenance Manual ✿

Code: 20.E.02 Rel. 06/14

This manual has to be considered an integral part of the product; it includes the basic information for a proper installation, setting at work and maintenance of the actuator.

SERVOMECH does not assume the responsibility for the direct or indirect consequences of any improper use, not correspondent to the declared performances of the actuator indicated in the technical catalogues.

The non-compliance with the use and maintenance instructions indicated in the manual will cause the immediate invalidation of the warranty terms, and will completely release SERVOMECH from any responsibility for possible damages caused to things or people.

SERVOMECH and its authorised distributors' services is at the disposal of customers in order to give, during the selection and/or design process, all technical support necessary for a proper application of the actuators.

SERVOMECH reserves the right to introduce improving changes and variations to the products and to this manual without notifying it.

SUMMARY

1. INSTALLATION AND COMMISSIONING

1.1. Positioning and fixing of actuator	5
1.2. Electric connection	5
1.3. Shifting direction check	6
1.4. Check of extreme working positions	7
1.5. Commissioning	8

2. MAINTENANCE

2.1. Lubrication	9
2.2. Maintenance reference table	9

3. DISASSEMBLING AND REASSEMBLING INSTRUCTIONS





3.0. Before you start	10
3.1. Disassembly of stroke limit device	10
3.2. Actuating part disassembly	10
3.3. Wormgearbox disassembly	11
3.4. Before you start reassembly	11
3.5. Wormgearbox reassembly	12
3.6. Actuating part reassembly	13
3.7. Mounting of stroke limit device	13

APPENDIX

- Cross-section drawing with spare parts list

SAFETY INSTRUCTIONS

- **Be careful never to operate damaged products!**
- **Read these operating instructions carefully before beginning set-up and installation!**
- **Always follow the relevant safety instructions. They are indicated as follows:**

	ELECTRICAL HAZARD - working with live voltage
	MECHANICAL HAZARD - actuator or plant could be damaged, there is danger for operator
	VERY IMPORTANT INSTRUCTIONS
	PAY ATTENTION ON ...

1. INSTALLATION AND COMMISSIONING

1.1. POSITIONING AND FIXING OF ACTUATOR

1.1.1. If the length of the actuator has be set differently (actuator more extended or more retracted) in order to make its installation easier, it has to be done as follows:



DO NOT SET THE LENGTH OF THE ACTUATOR OVER ITS EXTREME VALUES (MINIMUM - L_a and MAXIMUM - L_c , see Fig. 1.1), indicated on the check sheet enclosed to the despatch (see an example in APPENDIX)!

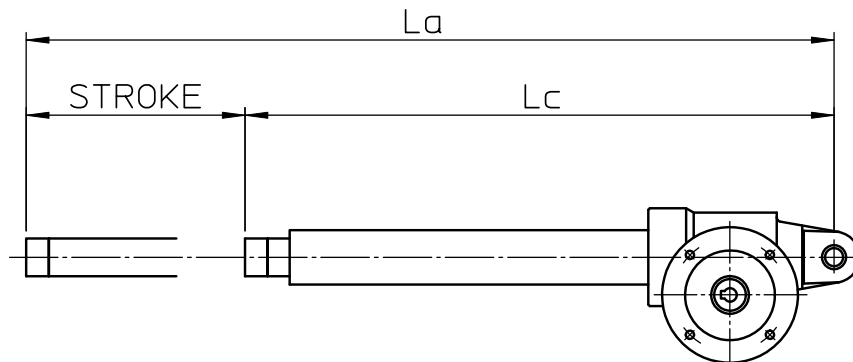

Figure 1.1: Extreme values of actuators length - minimum (L_c) and maximum (L_a)

A) ACTUATORS WITHOUT ANTI-TURN DEVICE (AR):

- screw - unscrew the push rod manually;

B) ACTUATORS WITH ANTI-TURN DEVICE (AR), WITH ELECTRICAL MOTOR WITHOUT BRAKE:

- turn the motor fan manually;

C) ACTUATORS WITH ANTI-TURN DEVICE (AR), WITH ELECTRICAL MOTOR WITH BRAKE OR WITH ELECTRICAL MOTOR WITHOUT FAN:

- take off the electric motor
- turn the input shaft manually, in order to reach the push rod to the necessary position.

1.1.2. Check that all plant fixing elements are well machined and cleaned, and that they fit the dimensions of the actuators fixing elements they have to be fixed to.

1.1.3. Fit the actuator to the plant in order to have **ONLY** axial load applied to the actuator (see Fig. 1.2). **RIGHT WORKING OF THE ACTUATOR AND PLANT CAN NOT BE GUARANTEED IF SIDE OR NOT AXIAL LOAD ARE APPLIED TO THE ACTUATOR.**



1.2. ELECTRIC CONNECTION

1.2.1. Connect the stroke limit device (if present) and the electric motor to the control unit of the plant (find an example of **Electrical data sheet** enclosed in **APPENDIX**). The electric connections of the motor into the terminal board have to be carried out following the precautions indicated by manufacturers (see Fig. 1.3). For actuators with DC motor or AC single-phase motor, it is possible to fix the shifting direction immediately.

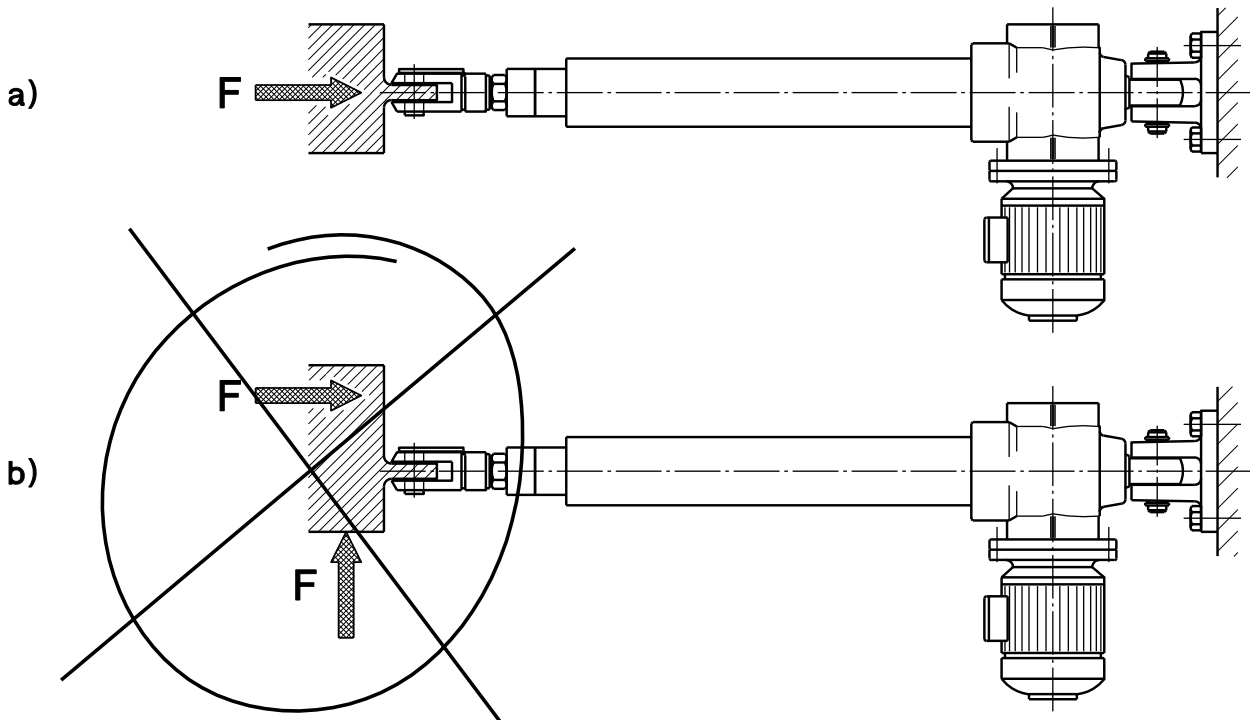

Figure 1.2: Load on actuator: a) correct; b) non correct



1.3. SHIFTING DIRECTION CHECK

A) ACTUATORS WITH ELECTRIC MOTOR:

1.3.1. Check if the push rod shifting direction is compatible to the indications on the control unit, by powering the electric motor on **VERY BRIEFLY**. If not:

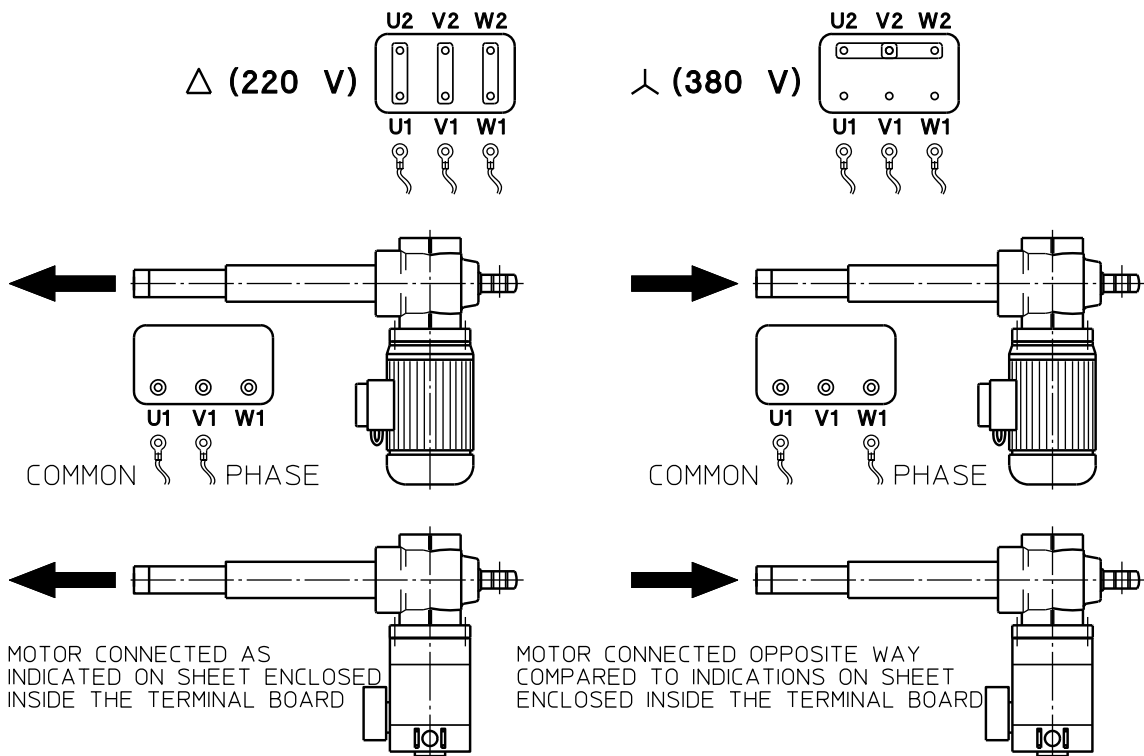

Figure 1.3: Connection of electric asynchronous motor in terminal board

- a) AC three-phase-motor connection
- b) AC single-phase-motor connection
- c) DC motor connection

- A) ACTUATOR WITH THREE-PHASE MOTOR: invert any wire pair (U1↔V1, or U1↔W1, or V1↔W1) into the terminal board, see Fig. 1.3 a;
- B) ACTUATOR WITH SINGLE-PHASE MOTOR: change the contact V1↔W1, see Fig. 1.3 b.
- C) ACTUATOR WITH DIRECT CURRENT MOTOR: invert contacts of the two motor supply cables.

B) ACTUATORS WITHOUT ELECTRIC MOTOR:

- 1.3.1. Note that there is a self-sticking label on the external tube, near the housing (on Fig. 1.4, too), which helps to clarify the relationship of the input shaft rotation direction with pushrod linear movement direction.

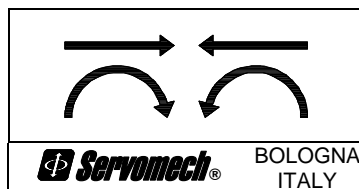

Figure 1.4: Label on external tube

- 1.3.2. Turn the input shaft, in order to see the shifting direction.



1.4. CHECK OF EXTREME WORKING POSITIONS

- 1.4.1. Check if the extreme dimensions of the actuator are compatible with extreme positions of the plant component that has to be moved.

A) ACTUATOR WITHOUT STROKE LIMIT DEVICE:

- measure the initial length of the actuator;
- run the actuator GRADUALLY from the control unit, in order to reach the plant to its more distant extreme position;



**CHECK CONTINUOUSLY THE CURRENT ACTUATORS LENGTH DURING THE MOTION!
IT MUST NOT GO OVER THE EXTREME VALUES L_a and L_c !**

- Repeat the same procedure for the other plant extreme position.

B) ACTUATOR WITH ELECTRIC STROKE LIMIT DEVICE:

- measure the initial length of the actuator;

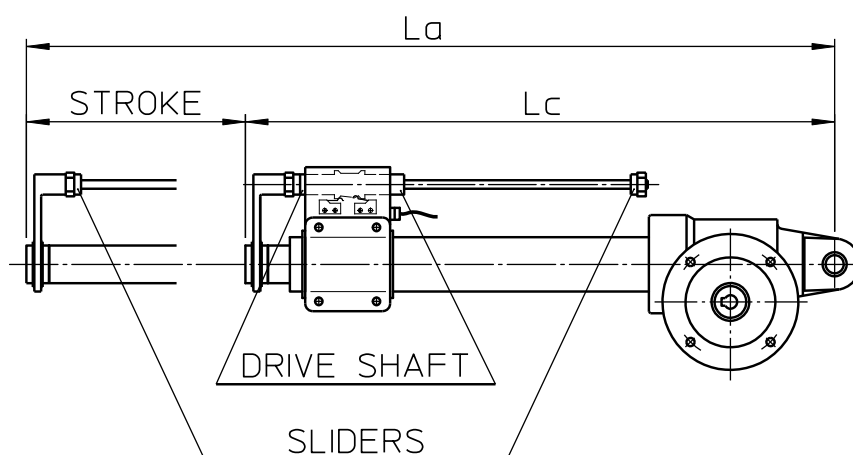
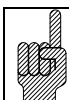

Figure 1.5: Actuator with electric stroke limit device

- run the actuator GRADUALLY from the control unit, in order to reach the plant to its most distant extreme position.



**CHECK CONTINUOUSLY THE CURRENT ACTUATORS LENGTH DURING THE MOTION!
IT MUST NOT GO OVER THE EXTREME VALUES L_a and L_c !**

- if necessary, adjust the axial position of the corresponding slider of the electric stroke limit device (see Fig. 1.5), in order to adjust the extreme position of the actuator;
- repeat the same procedure for the other plant extreme position.

C) ACTUATOR WITH MAGNETIC STROKE LIMIT DEVICE:

- measure the initial length of the actuator;

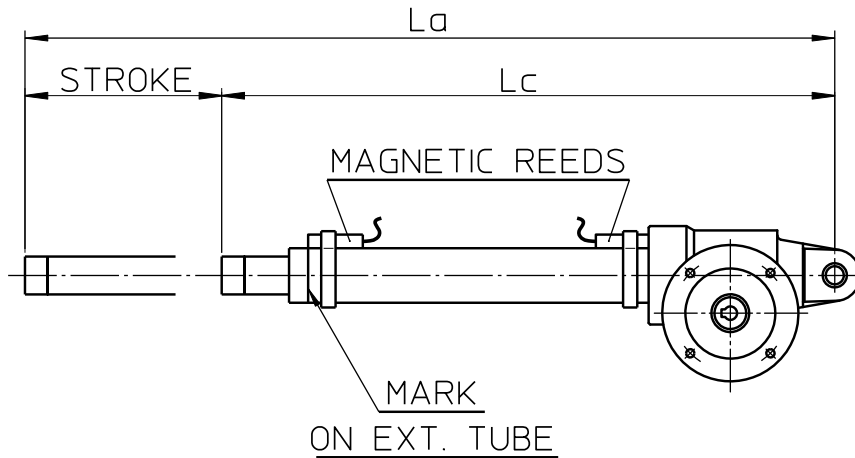
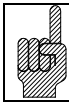

Figure 1.6: Actuator with magnetic stroke limit device

- run the actuator GRADUALLY from the control panel, in order to reach the plant to its most distant extreme position.



**CHECK CONTINUOUSLY THE CURRENT ACTUATORS LENGTH DURING THE MOTION!
IT MUST NOT GO OVER THE EXTREME VALUES L_a and L_c !**

- if necessary, adjust the position of the corresponding magnetic reed (see Fig. 1.6), in order to adjust the extreme position of the actuator. **Pay attention that the extended actuator position reed must not be placed over the circular mark on the external tube!**
- repeat the same procedure for the other plant extreme position.



1.5. COMMISSIONING

- 1.5.1. Carry out one complete working cycle, without load.
- 1.5.2. Carry out many complete working cycles, increasing gradually the load, until the load is maximum.

2. MAINTENANCE

2.1. LUBRICATION

ACTUATOR	WORM GEARBOX		ACTUATING PART		
	LUBRICANT	Q.TY [g]	LUBRICANT	QUANTITY	
				FOR STROKE 100 mm [g]	FOR ANY ADDITIONAL 100 mm OF STROKE [g]
ATL 20	AGIP Grease SLL 00	30	AGIP Grease SM 2	20	20
ATL 25 - 28		30		30	25
ATL 30		40		40	30
ATL 40		50		50	40
BSA 20	AGIP Grease SLL 00	30	LUBCON Thermoplex ALN 1001	10	10
BSA 25 - 28		30		15	12
BSA 30		40		20	15
BSA 40		50		25	20

2.2. MAINTENANCE REFERENCE TABLE



The plant must be stopped and power supply must be off BEFORE beginning any maintenance operation.

The main periodical maintenance operations are listed in the table below.

The frequency of maintenance operations will depend on the application and on the environmental conditions. The recommended frequency of maintenance operations in the table below is relevant for the following operating conditions:

- environmental temperature: (20 ÷ 25)°C
- industrial application functioning;
- duty cycle: 20%/hour, for actuators Series ATL
100%/hour, for actuators Series BSA
- (5 ÷ 6) working hours a day.

Table 2.3: Main periodical maintenance operations

FREQUENCY	CHECKLIST	POSSIBLE ACTION
TWO WEEKS	LUBRICANT LOSS	IDENTIFICATION OF LUBRICANT LOSS AND ELIMINATION OF ITS CAUSE; ADDITION OF LUBRICANT
MONTHLY	SCREW - NUT BACKLASH	VERIFICATION OF WORKING PERIOD AND CONDITIONS; CONTACT SERVOMECH

3. INSTRUCTIONS FOR DISASSEMBLY AND REASSEMBLY

3.0. BEFORE YOU START



**The power supply must be off
BEFORE beginning any disassembly or reassembly operation!**

For disassembly, substitution of actuator parts and the corresponding reassembly you will need the following:

- specialized staff,
- appropriate equipment,
- basic knowledge of actuator construction,
- correct procedure must be followed,
- current national/regional health and safety regulations must also be observed.

In cases of uncertainty, please contact SERVOMECH or its authorised distributors' technical services.

The following descriptions refer to the numeric position of parts, as indicated on the corresponding drawings (find them in APPENDIX).

3.1. DISASSEMBLY OF STROKE LIMIT DEVICE

A) ELECTRIC STROKE LIMIT DEVICE

- 3.1.1. Take off the seeger-ring (it. 17, SPARE PARTS LIST OF ELECTRIC SLD).
- 3.1.2. Unscrew screws and take them off together with their washers (it. 14 e 12, SPARE PARTS LIST OF ELECTRIC SLD).
- 3.1.3. Take off axially the device from the push rod side.

B) MAGNETIC STROKE LIMIT DEVICE

- 3.1.1. Unloose the fixing screws of the reed fastening clamps.
- 3.1.2. Take off the reeds.

3.2. ACTUATING PART DISASSEMBLY

A) ACME SCREW ACTUATORS (Series ATL)

- 3.2.1. Warm up the end part of the push rod (it. 14) near the threaded end (it. 20) to loosen the threadseal - threadlock; fix the push rod in order to prevent its rotation and unscrew anti-clockwise the threaded end.
- 3.2.2. Warm up the housing (pos. 1) near the external tube (it. 13 or 86) in order to loosen the threadlock - threadseal; take off the grub (it. 89) and take off the threaded insert (it. 6) together with the external tube, unscrewing it anti-clockwise; take off the threaded insert from the external tube, unscrewing it anti-clockwise.
- 3.2.3. Screw completely the push rod clockwise, and take off the seeger-ring (it. 35).
- 3.2.4. Unscrew manually the push rod (it. 14) from the screw (it. 15 or 74), together with bronze nut (it. 5, 75, 76 or 84) and guide bush (it. 24). Take out the guide bush from the push rod.



DISPOSE CAREFULLY OF THE LUBRICANT!

- 3.2.5. If necessary, warm up the end part of the push rod near the nut, and then unscrew anti-clockwise the nut.

B) BALL SCREW ACTUATORS (Series BSA)

- 3.2.1. Warm up the end part the push rod (it. 14) near the threaded end (it. 20) to loosen the threadseal - threadlock; fix the push rod in order to prevent its rotation and unscrew anti-clockwise the threaded end.
- 3.2.2. Warm up the housing (pos. 1) near the external tube (it. 13 or 86) in order to loosen the threadlock - threadseal; take off the grub (it. 89) and take off the threaded insert (it. 6) together with the external tube, unscrewing it anti-clockwise; take off the threaded insert from the external tube, unscrewing it anti-clockwise.



To check the ballnut or ball conditions (or for any other operation on the actuating part), contact SERVOMECH or its authorised distributors' technical services!

3.3. WORMGEARBOX DISASSEMBLY

- 3.3.1. If present, take off the electrical motor, by unscrewing the four fixing screw anti-clockwise.
- 3.2.2. Extract the nilos (it. 41).
- 3.2.3. Worm disassembly:
- if present, take off the motor fixing flange,
 - take off oil seals and covers on the worm axis,
 - take off seeger-rings and, if present, shim washers,
 - push the wormshaft, so it comes out from the opposite side of the housing.

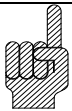

**Be very carefull in order to not damage the wormwheel:
do not move the wormshaft axially more then necessary to let the wormwheel free.**

- 3.3.4. Pull the acme/ball screw axially, so the assembly comes out from the housing.
- 3.3.5. Take out the wormshaft with its bearings, and take off the bearings from the wormshaft.

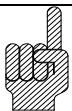

DISPOSE CAREFULLY OF THE LUBRICANT!

- 3.3.6. Warm up the nut (it. 42) in order to loosen the threadlock and unscrew the nut anti-clockwise.
- 3.3.7. Take off the wormwheel - bearings assembly from the acme/ball screw, BY DISASSEMBLING ONE COMPONENT AT A TIME.

3.4. BEFORE YOU START REASSEMBLY

3.4.1. List of locking - sealing materials

Locking - sealing materials used during the assembly of the actuator are as follows:

- Threadlock applications: LOCTITE 242 and LOCTITE 270 or equivalent
- Planeseal applications: LOCTITE 574 or equivalent
- Threadseal applications: LOCTITE 577 or equivalent

Before you start the reassembly, read carefully their instructions of use, and follow the indicated application procedure during the reassembly, when and where using these materials.

However, the basic instructions about the use of them can be found in this chapter.

3.4.2. General

- Before being mounted, all parts, where lock - seal material has to be applied on, must be well cleaned and washed with the **NITRO-SOLVENT**.
- All prepared surfaces and threads, wher the locking - sealing material is to be applied on, must not be touched by fingers (or contaminated in some other way) any more.

3.4.3. Thread applications

- Carry the threadlock - threadseal on the external thread, and distribut it by brush uniformly on the thread. A small quantity should be applied at the beginning of the internal thread.
- Screw the internal thread into the external one in the vertical position, turning it completely twice forward - once backward.
- Let the threadlock - threadseal polimerize for (3 - 5) min.

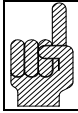

**All threaded parts connected by threadlock must be also tightened
(find the torque values in the following table).**

Tabella 3.1

ACTUATOR SIZE	20	25	30	40
TORQUE [Nm]	15	25	40	70

3.4.4. Applications on plane contact surfaces (ex. housing - flange)

- Carry the planesealing material on the contact surface of one component (ex. flange).
- Mount the parts and fix them (ex. mount the flange onto the housing and fix it with the four fixing screws).

3.5. WORMGEARBOX REASSEMBLY

3.5.1. Prepare the wormwheel - acme/ball screw assembly:

A) actuator without safety clutch (FS):

- fit the bearings (it. 44) on the bushes (it. 7), as indicated on Fig. 3.1.a,
- fit the bearings already on the bushes, the wormwheel (it. 3), the spacer (it. 8) and the key (it. 39) on acme/ball screw, as indicated on the corresponding cross-section drawing; carry some threadlock over the nut and screw end right-hand metric thread and tighten the nut (pos. 42). For bearings mounting direction see Fig. 3.1.b.

B) actuator with safety clutch (FS):

- fit one bearing (it. 44) on the bush (it. 7), as indicated on Fig. 3.1.a, and the other bearing on the bush (it. 9),
- fit the bearings already on the bushes and the safety clutch assembly (the wormwheel (it. 4) on the bush (it. 10), the bush (it. 11), the disk-springs (it. 21) and the spacer (it. 12)) on acme/ball screw, as indicated on the corresponding cross-section drawing; carry some threadlock over the nut and screw end right-hand metric thread and tighten the nut (pos. 42). For bearings mounting direction see Fig. 3.1.b.

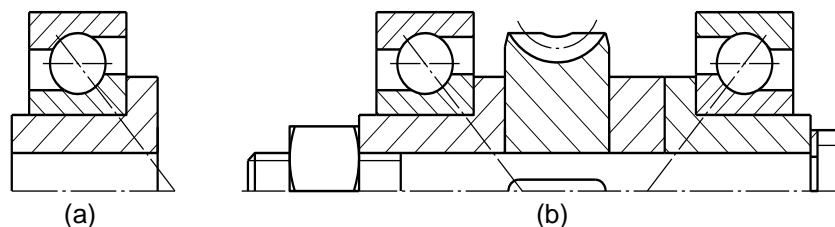

Fig. 3.1: a) Mounting of bearings on bushes
b) Mounting of bearings on screw

3.5.2. Push the assembly prepared in 3.5.1 into the housing (already fitted vertically on the vice with aluminium jaws), until it stops mechanically.

- 3.5.3. Fit the nilos (it. 41) on the bearing, and screw the threaded insert (it. 6) into the housing - the threadlock (ex. LOCTITE 270, when actuator supplied with antiturn device AR) or threadseal must be applied before screwing the threaded insert.



The threaded insert must be screwed in enough to prevent axial backlash of bearings, but axial bearings must not be preloaded!

- 3.5.4. Fill the lubricant into the housing (for type and quantity see § 2.3).
- 3.5.5. Fit the worm shaft with its bearings into the housing, as indicated on the corresponding cross-section drawing. Insert seeger-rings and shim washers, when necessary. The worm shaft assembly and adjustment of its bearings is a typical wormgearbox assembly operation!
- 3.5.6. Fit oil seals and covers on the wormshaft.
- 3.5.7. RUNNING TEST: if runned by hand, the wormshaft should turn continuously, without sticking. Otherwise, find out which assembly step has not been done correctly, disassembly the wormgearbox following indications in § 3.3, and assembly again as above described.

3.6. ACTUATING PART REASSEMBLY

A) ACME SCREW ACTUATORS (Series ATL)

- 3.6.1. Screw the bronze nut (it. 5, 75, 76 or 84) clockwise onto the push rod (it. 14), by carrying over some threadlock (ex. LOCTITE 270), and tighten it with fixing torque (see Table 3.1).
- 3.6.2. Screw the push rod clockwise onto the acme screw (it 15 or 74) completely.
- 3.6.3. Lubricate the acme screw (for type and quantity of the lubricant see § 2.3).
- 3.6.4. Fit the guide bush (it. 24) and the seeger-ring (it. 35).
- 3.6.5. Tighten the external tube (it. 13 or 86) clockwise onto the housing (it. 1), by carrying over the thread some threadseal (when there is not the anti-turn device AR) or theadlock (ex. LOCTITE 270, when there is the anti-turn device AR).
- 3.6.6. Screw the grub (it. 89) completely, by carrying over the thread some threadlock.
- 3.6.7. Screw the threaded end (it. 20) clockwise onto the push rod, by carrying over the thread some threadlock (ex. LOCTITE 270), and tighten it with fixing torque (see Table 3.1).

B) BALL SCREW ACTUATORS (Series BSA)

- 3.6.1. Tighten the external tube (it. 13 or 86) clockwise onto the housing (it. 1), by carrying over the thread some threadseal (when the anti-turn device AR is not present) or theadlock (ex. LOCTITE 270, when the anti-turn device AR is present).
- 3.6.2. Screw the grub (it. 89) completely, by carrying over the thread some threadlock.
- 3.6.3. Screw the threaded end (it. 20) clockwise onto the push rod, by carrying over some threadlock (ex. LOCTITE 270), and tighten it with fixing torque (see Table 3.1).

3.7. MOUNTING OF STROKE LIMIT DEVICE

The procedure of the mounting of stroke limit device is the opposite of the procedure described in § 3.1.

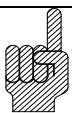

WHEN THE REASSEMBLY IS FINISHED, LET THE ACTUATOR REST FOR AT LEAST 3 HOURS, SO ALL LOCKING - SEALING MATERIALS POLYMERIZE!

APPENDIX

SERVOMECH s.p.a.

Via Monaldo Calari, 1 40011 Anzola Emilia (BO) ITALY

Phone: + 39 051 6501711 Fax: + 39 051 734574 e-mail: info@servomech.it