

Couplings

Type GEL



Stock photo

Document-/Rev.-No.:

TR-V-TI-GB-0430-02

10/20/2014

Advantages

- _ 45000 min⁻¹ possible
- _ Galvanic corrosion reduction
- _ Self-centering ring fastener
- _ Compact simple construction
- _ Easy installation

Description

The fin-couplings DIN.AL. 500-S, belonging to series "GEL" are usually used for the connection of tachogenerators, encoders, contactors, motors, measuring instruments and for every application where a constant rotational velocity in the four quadrants is required and where an absolute torque rigidity is required, even when the shafts coupling is not perfectly lined up.

Projected according to DIN 740, these couplings can bear angular, radial and axial misalignments, without causing stress on the connected shafts, thanks to their peculiar construction. Their special construction and the used materials allow to use them within a temperature of -30°C to $+200^{\circ}\text{C}$.

High-quality materials are used to produce the fin-couplings, series "GEL".

A light no-magnetic alloy, which was subjected to an anticorrosion galvanic process, is used for the bodies and the hubs. The connecting fins, a very important part of the given coupling, have to ensure both the torque transmission and the elasticity of the system. For this reason they are made of a special bronze alloy. Special rivets ensure the connection of the fins to the hub and to the body.

Subject to change.

Couplings

Type GEL

Document-/Rev.-No.:

TR-V-TI-GB-0430-02

10/20/2014

Mechanical characteristic Data

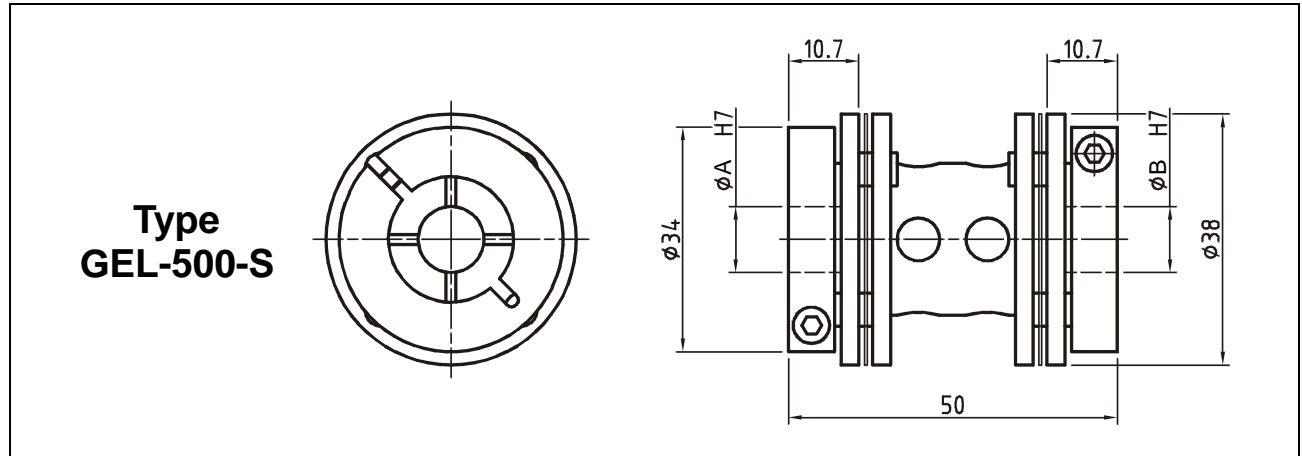

Assembling

The great compactness of the fin-couplings makes the assembling easy, even for difficult mounting positions. In the series GEL-500-S the hub fixing into the shafts occurs with a patented special self-blocking system. The holes of the hubs are manufactured according to tolerance ISO H7.

For a correct assembling, it is advisable to manufacture the connecting shafts according to the tolerance ISO H7. In order to exploit the elastic field of the couplings in the best way check the alignment of the connecting shafts of the equipment, before the assembling, to avoid angular and radial misalignments as much as possible. After the assembling check that no anomalous pressure occurs on the connecting fins, because of a too high axial misalignment. The maximum angular, radial and axial misalignments value are shown in the table below. It is very important to say that the mentioned values cannot be used at the same time.

| Type | ØA H7 | ØB H7 | Article - Nr. |
|-----------|-------|-------|---------------|
| GEL-500-S | 10 | 14 | 34-000-181 |
| | 10 | 10 | 34-000-182 |
| | 10 | 12 | 34-000-183 |
| | 12 | 12 | 34-000-184 |
| | 12 | 14 | 34-000-185 |
| | 14 | 14 | 34-000-186 |

| Definition | Nominal Torque | Max. Torque | Axial misalignment max | Radial misalignment max | Angular misalignment max | Moment of inertia | Maximum speed | Dynamic torsional stiffness x10 ² | Weight |
|------------|----------------|-------------|------------------------|-------------------------|--------------------------|-------------------------------------|-------------------|--|--------|
| Symbol | T_N | T_s | ΔW_a | ΔW_r | ΔW_w | J | n max | $C_{w\ dyn}$ | m |
| Unit | Nm | Nm | mm | mm | rad | Kg m ² x10 ⁻⁶ | min ⁻¹ | Nm/rad | Kg |
| GEL-500-S | 1,53 | 2,20 | 0,8 | 0,7 | 0,02618 | 11,166 | 45.000 | 24,815 | 0,067 |

Subject to change.